

Surface grinding	Machine	Machine type	Capacity (mm)	Additional information
Surface and Profilegrinding	Danobat	SGD 80/30/15 CNC	8000 x 3000 x 1500	Max. 30,000 kg / Incl. universal grinding head
Surface and Profilegrinding	Waldrich Coburg	30-15SPS CNC	7000 x 1750 x 1500	Incl. universal grinding head
Surface and Profilegrinding	WMW-Heckert	Aschersleben	3000 x 1500 x 1000	Incl. uni-spindle
Surface and Profilegrinding	Rosa	Silver 60.9 CNC	6250 x 900 x 700	
Surface and Profilegrinding	Danobat	RTM 6000 CNC	6000 x 750 x 650	Concave and Convex
Surface and Profilegrinding	Danobat	RTL 2000 CNC	2000 x 750 x 650	Concave and Convex
Surface and Profilegrinding	Okamoto	ACC358 CNC	3500 x 1000 x 600	
Surface and Profilegrinding	Okamoto	ACC258 CNC	2500 x 800 x 600	
Surface and Profilegrinding	Okamoto	ACC208 CNC	2000 x 1000 x 600	
Surface and Profilegrinding	Blohm	Planomat CNC	1200 x 600 x 550	
Surface and Profilegrinding	Proth	PSGP-1022AHR	2200 x 1000 x 500	
Surface and Profilegrinding	Okamoto	125 EX CNC	1200 x 500 x 500	
Surface and Profilegrinding	Okamoto	PRG8 CNC	Ø 900 x 250	Round table machine
Surface and Profilegrinding	Jung	JF525 CNC	500 x 200 x 300	3 machines
Disc grinding	Reform	AR60 type 19 CNC (220 kW)	6000 x 1350 x 550	
Disc grinding	Reform	AR41 type 19 CNC (300 kW)	4100 x 1350 x 550	
Disc grinding	Camut	V2-44C (80 kW)	4000 x 850 x 750	
Disc grinding	Göckel	G50 GB65	5500 x 150 x 150	3 pieces / Tiltable magnet
Pressing	Sahinler	Portalpress DK- S/400 ton	4000 x 2500 x 600	400 tons

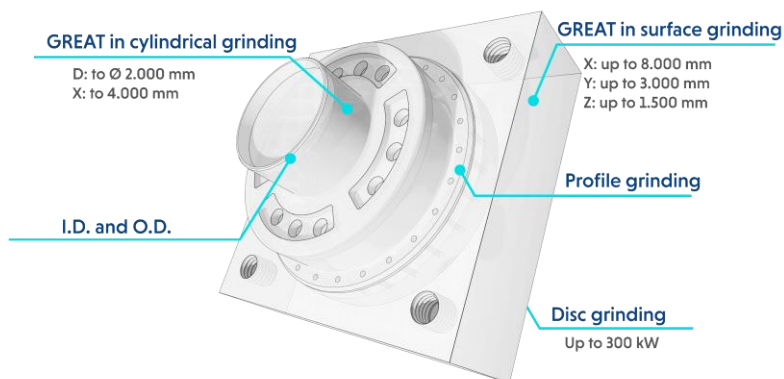

Cylindrical grinding	Machine	Machine type	Capacity (mm)	Additional information
Vertical grinding	Kehren	Ri 12-4	Ø 1500 x 950	Surface grinding In- and externally cylindrical grinding Coördinates grinding
Vertical grinding	Kehren	Ri 8-4	Ø 1200 x 700	Surface grinding In- and externally cylindrical grinding Coördinates grinding and hardturning
Vertical grinding	Berthiez	VGM-1600 CNC	Ø 2000 x 1300	In- and externally cylindrical grinding
Vertical grinding	DMG Mori	Vertical Mate 55	Ø 500 x 300	Surface grinding In- and externally cylindrical grinding
Cylindrical grinding	Danobat	G91-S CNC	Ø 1000 x 4000	Max. 5000 kg
Cylindrical grinding	AMC-Schou	R3000	Ø 670 x 3000	
Cylindrical grinding	WMW-Heckert	SA6 x 1500	Ø 550 x 1500	
Cylindrical grinding	Fermat	BUB E50/2000 CNC	Ø 500 x 2000	
Cylindrical grinding	Kellenberger	1500-U/R	Ø 350 x 1500	
Cylindrical grinding	Studer	S40 CNC	Ø 350 x 1000	With C-As
Cylindrical grinding	Studer	S30 Leanpro CNC	Ø 350 x 1000	With B-As
Cylindrical grinding	Göbel		Ø 800 x 300	Special cylindrical knifegrinders
Cylindrical grinding	Göckel	R5 R6		Special cylindrical knifegrinders
Centerless grinding	Cincinnati	No.2	Ø 2 - Ø 75	
Centerless grinding	Herminghausen	SRII	Ø 1 - Ø 50	

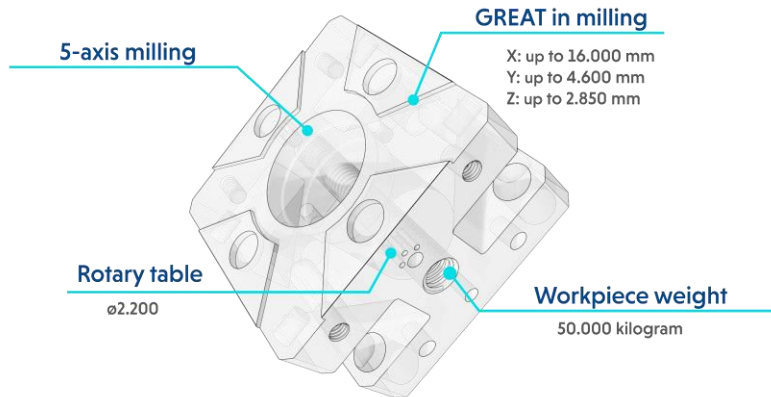

Milling	Machine	Machine type	Capacity (mm)	ATC	Additional information
Milling	PAMA	Vertiram 2000	14000 x 4600 x 2850	384 HSK100	5-axis, simultaneous, four interchangeable heads
Milling	PAMA	Vertiram 2000	14000 x 4600 x 2850	180 HSK100	5-axis, simultaneous, four interchangeable heads
Milling	Unisign	Uniport 6000	16000 x 4000 x 1300	121 SK50	5-axis, indexed per 2,5 degrees (max. 50.000 kg)
Milling	Unisign	Uniport 6000	8000 x 3500 x 1300	200 HSK100	5-axis, indexed per 2,5 degrees
Milling	Unisign	Uniport 6000	8000 x 3500 x 1300	112 SK50	5-axis, indexed per 2,5 degrees
Milling	Unisign	Uniport 6000	8000 x 3500 x 1500	112 HSK100	5-axis, indexed per 2,5 degrees two interchangeable heads
Milling	Unisign	Uniport 6000	8000 x 2500 x 1300	99 SK50	5-axis, indexed per 2,5 degrees
Milling	Unisign	Uniport 4000	6000 x 1500 x 400	39 SK40	3-axis
Milling	Matec	40-P	16000 x 3500 1500	100 SK50	5-axis, simultaneous
Milling	Matec	50HVU	6000 x 1400 x 1800	172 HSK100	6-axis, simultaneous, circular table Ø2200 mm
Milling	Matec	40-HV	8000 x 1000 x 1100	152 SK50	4-axis, simultaneous
Milling	Matec	30-HV	3000 x 800 x 700	365 SK40	5-axis, indexed per 1 degree, circular table Ø700 mm
Milling	Matec	30-HV	3000 x 800 x 700	268 SK40	5-axis, simultaneous
Milling	Hedelius	T10-3.600	3600 x 1000 x 1000	192 HSK100	5-axis, simultaneous, indexed per 1 degree, circular table Ø1000 mm
Milling	Hartford	VMC 1270	1270 x 635 x 635	24 SK40	3-axis

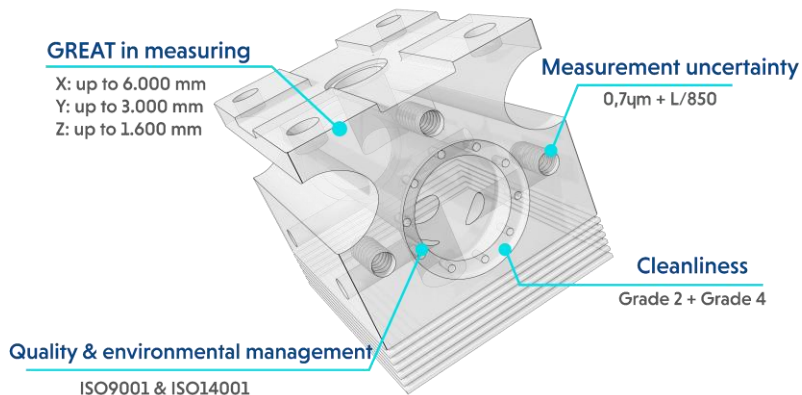

Measuring	Machine	Machine type	Capacity (mm)	Additional information
Measuring	Leitz	PMM-G 60.30.16	6000 x 3000 x 1600	Max. measurement uncertainty 2,8µm + L/400
Measuring	Leitz	PMM-C Ultra 24.16.7	2400 x 1600 x 700	Max. measurement uncertainty 0,7µm + L/850
Measuring	Mitutoyo	Crysta Apex 9206	2000 x 900 x 600	Max. measurement uncertainty 1,9µm + L/300
Measuring	Mitutoyo	Crysta Apex 574	700 x 500 x 400	Max. measurement uncertainty 1,9µm + L/300